



MF133 High Protection Peristaltic Pump

Lead Fluid MF133 high protection peristaltic pump is designed and developed specifically for pharmaceutical and industrial applications. It has a high protection level of IP66/IP67, and has the ability to prevent dust and short-term liquid immersion. It can operate stably for a long time in harsh environments such as dust, humidity, weak acid, alkali, and salt mist.

Feature

- Aluminium alloy shell with exquisite craftsmanship and streamlined appearance, cast aluminum spray coated shell with light weight, good heat dissipation, and strong corrosion resistance.
- Integrated structure, with strong integrity. The pump head and driver are integrated, eliminating installation difficulties.
- 7 inch large screen, clear and easy to operate with a seven inch color LCD touch screen
- Servo motor drives high-precision operation, high torque, and low noise
- Multiple working modes: Offers flow mode, time dispensing mode, external control mode for flexible adaptation to various scenarios.
- Multiple sensing technologies for lid opening and pump stopping, as well as liquid leakage and pump stopping (optional), enhance safety.
- Three-level user permission management: Secure protection against unauthorized parameter changes
- Selected top-tier brand materials: Quality assured through meticulous selection of materials from top brands.
- Patented calibration method: Shortens calibration time by three times compared to conventional methods, reduces liquid usage by three times.

Application areas: pharmaceuticals, industrial applications, etc

Technical Parameter

Parameter	MF133
Flow range	10-33000mL/min
Speed range	0.1-350rpm/min
Speed resolution	0.1rpm/min, speed accuracy within 0.2%
Working time	0.01-99.99S/M/H
Dispensing time	0-9999
Dispensing interval time	0.1-999.9S/M/H
Suction angle	0-360°
Adjust	Touch screen operation
Display	5 inch IPS color screen
Direction	Clockwise/counterclockwise
Power supply	AC 100-240V 50Hz-60Hz
Communication interface	RS485, RS232, Ethernet support Modbus protocol
External control signal input	Analog speed regulation method (0-5V/0-10V/4-20mA), control start/stop, clockwise/counterclockwise steering, external control signal photoelectric isolation
External control signal output	External control signal 5-24V wide range input, control start/stop, clockwise/counterclockwise steering, external control signal photoelectric isolation
Power consumption	<350W
Working environment	Temperature 0 ~ 40°C, relative humidity < 80%
Dimension(L×W×H)	440X383X295mm(pump head included)
Diver weight	24KG(pump head included)
IP grade	IP66/IP67

Applicable Pump Head and Tube, Speed, Flow

Drive Type	Pump Head	Channel	Tube	Single Channel Flow Rate(mL/min)
MF133	PL48	1	92#	9.4~33100 mL/min
		1	193#	8.2~28000 mL/min
		1	88#	4~13800 mL/min
		1	191#	2.2~7700 mL/min

Above flow parameters are obtained by using silicone tube to transfer pure water under normal temperature and pressure, in actually using it is effected by specific factors such as pressure, medium etc. Above for reference only.

Dimension(mm)

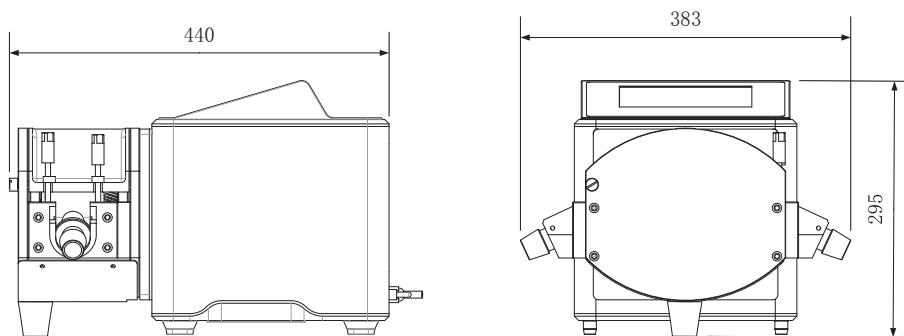

Statement: The final explanation right of above information belongs to Lead Fluid.